



BANLAW

"innovative refuelling specialists"

Products Guide



2008/2009

Banlaw can provide you with innovative, integrated and secure refuelling and hydrocarbon management systems to help you to control costs and ensure fuel security.

This Australian company has more than 30 years experience in the design, manufacture and implementation of world class hydrocarbon management systems for the mining, rail, fleet and port industries. It currently exports to 25 countries.

Banlaw's highly skilled staff have a reputation for technical expertise and a total commitment to quality and service. A commitment to research, development and quality ensures it provides systems and products to the highest standard. Its Quality Assurance System is accredited by Lloyds Register to AS/NZS ISO 9001.

Why Banlaw?

Banlaw has the people, products and services to manage all your refuelling and hydrocarbon management needs.

- World best technology - patented systems
- Built for tough operating conditions
- Customised, integrated systems and components
- Innovative R&D program
- Complete range of services and ongoing support.

Capabilities

- Audit services
- Consulting services
- Customised refuelling systems
- Customised hydrocarbon management systems
- Refuelling components
- Customised monitoring and reporting systems
- Ongoing technical support
- Maintenance services
- Refuelling facilities management
- Project management
- Diesel meter calibration.

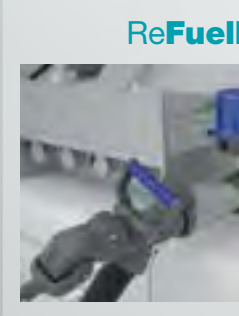
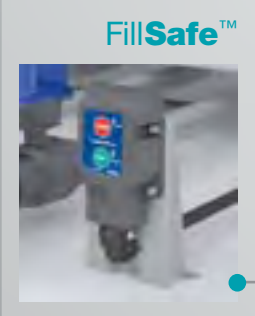

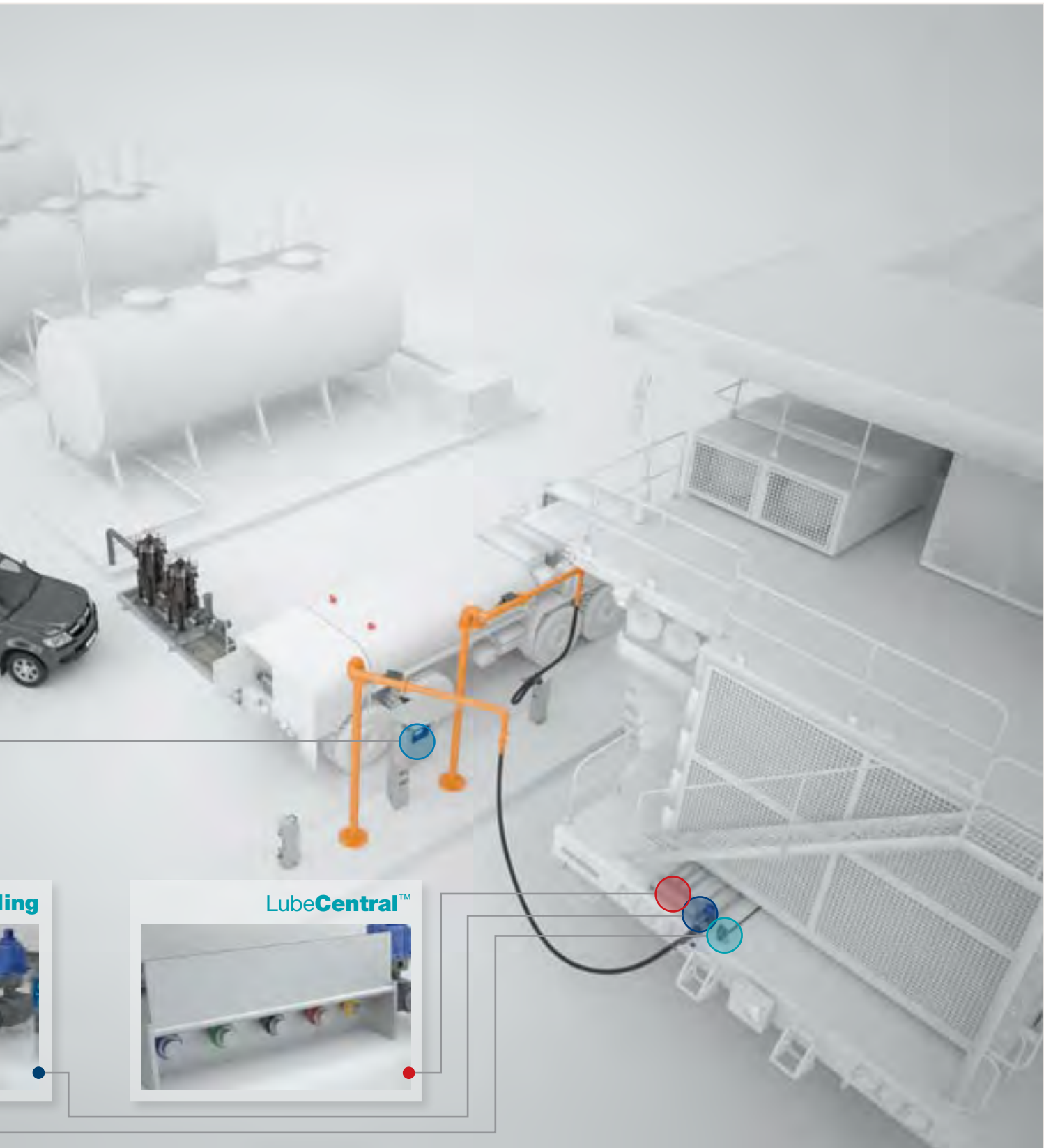

Sample site for illustration purposes only

Precise monitoring, reconciliation and centralised reporting of fuel use.

Banlaw FuelTrack™

Be in control. Save money.

Being able to secure and track fuel use is vitally important, particularly with high fuel prices.

Banlaw FuelTrack™ enables the precise monitoring, reconciliation and centralised reporting of any machine or vehicles' fuel or liquid use.

The system is readily adaptable to track, control and record the use of all hydrocarbons dispensed by vehicle, tank and distribution point. Vehicles and contractors are automatically identified by a range of different ID mechanisms including smart keys or Auto ID dry break nozzles and receivers.

FuelTrack's™ user friendly reporting system creates information rather than data, making it a powerful money saving, management tool for business.

FuelTrack™ assists with:

- fuel security
- environmental compliance
- stock reconciliation
- maintenance scheduling
- cost analysis
- the calculation of burn rates
- fuel ordering and
- claiming tax credits.



FuelTrack™ can help with compliant management for fuel tax credits and carbon trading schemes. It is accredited by the Australian Government's National Measurement Institute.

Ensure zero overflow and zero tank pressure in any environment.

Banlaw FillSafe™

Transfer fuel safely and efficiently.

Banlaw FillSafe™ ensures zero overflow, zero tank pressure and zero spillage during refuelling in any environment. Rates of 1000 litres (265 gallons) per minute can be achieved with no increase in tank pressure.

FillSafe™ works on a variety of mining and rail equipment including locomotives, excavators, haul trucks, and shovels.

The electrical level sensor on the fuel tank ensures automatic termination of fuel flow once the tank is full. FillSafe™ removes the guesswork and manual checking of tank levels.

The leak free connection between nozzle and tank also prevents contaminants entering the fuel tank - delivering improved performance outcomes and reduced downtime for each machine.



BFS - ZP2R

Fill Safe

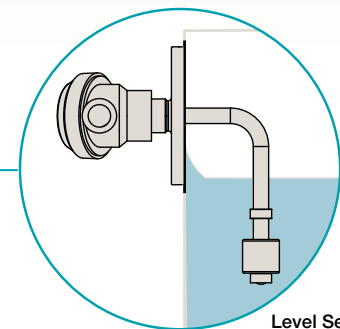

Level Sensor

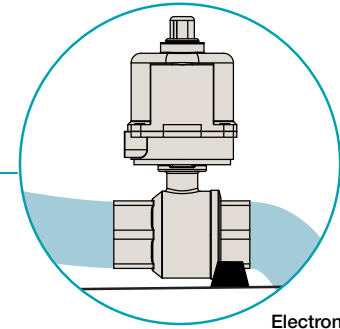

Electronic Ball Valve

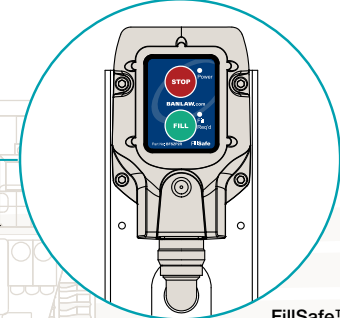

FillSafe™ Control Unit

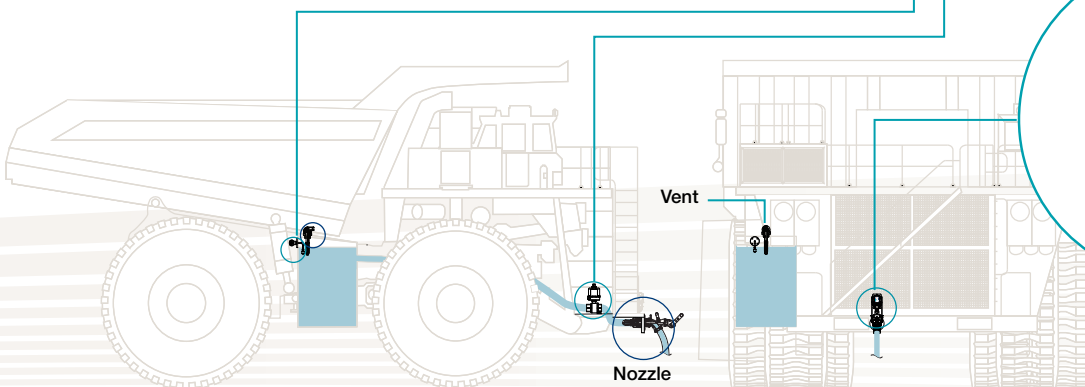

The associated diagram is for illustration purposes only and is not to scale



Nozzles - 1000 Series

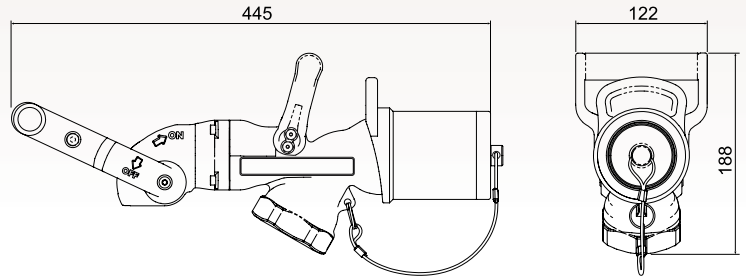
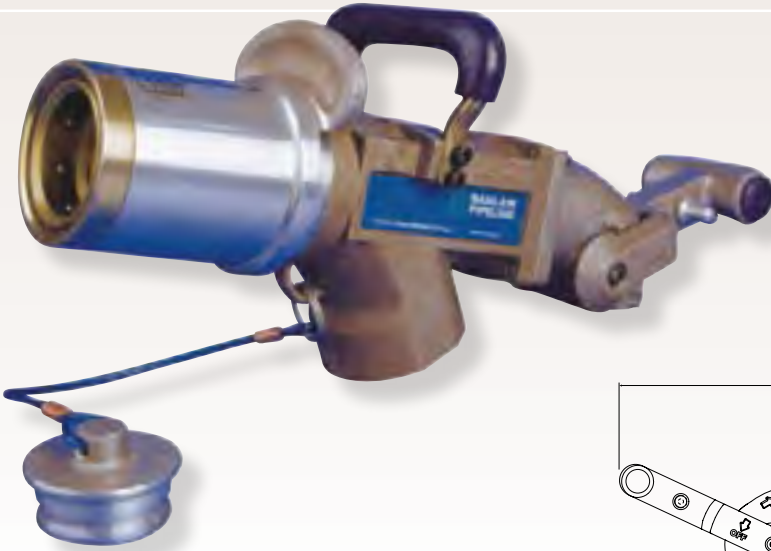

Flowrate Range Diesel

1000 Nozzle 400-1000 LPM / 106-264GPM

ReFuelling

Toughest

- Patented system built for tough operating conditions
- Stressed and wearing parts manufactured from steel not plastic

Safest

- Ergonomically designed - easy to use/latch
- Dependable ball locking mechanism means the nozzle cannot 'fly off'
- Automatic shut-off
- Anti-static hose is statically earthed

Cleaner Environment

- Dry break disconnection minimises leakage

Best Investment

- Highest possible flow rates
- Choice of 5 shut-off pressure settings
- Repairable, not disposable
- Compatible with **FillSafe™** and **FuelTrack™** systems

Mass (with plug): 4.3 kg (9.5 lbs)

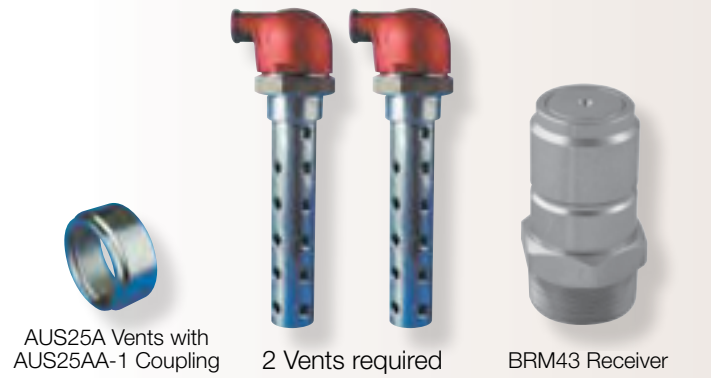

Q (L/min)	HL (kPa)
600	123
650	135
700	150
750	168
800	189
850	212
900	237
950	266
1000	297

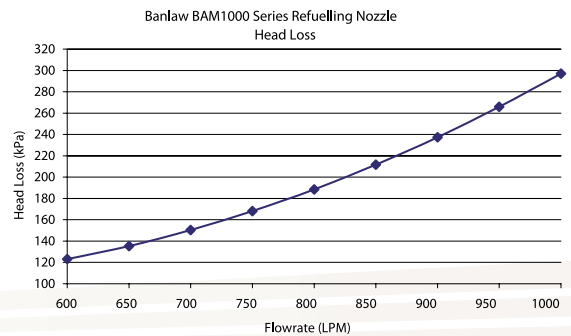

LEGEND:

- 1) All flow tests conducted using DIESOLINE fuel (SG=0.84, 5.5cSt nom.)
- 2) Head Loss (HL) includes Banlaw AUS43 Receiver
- 3) All gauge pressure measured within 2" bore

Nozzles - 800 Series

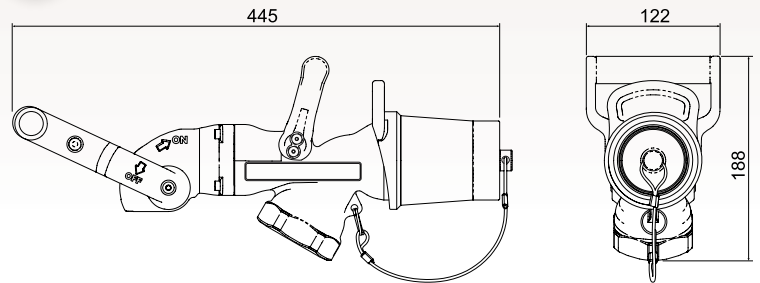

Flowrate Range Diesel

800 Nozzle 90-800 LPM / 24-211GPM

ReFuelling

Toughest

- Patented system built for tough operating conditions
- Stressed and wearing parts manufactured from steel not plastic

Safest

- Ergonomically designed - easy to use/latch
- Dependable ball locking mechanism means the nozzle cannot 'fly off'
- Automatic shut-off
- Anti-static hose is statically earthed

Cleaner Environment

- Dry break disconnection minimises leakage

Best Investment

- Highest possible flow rates
- Choice of 5 shut-off pressure settings
- Repairable, not disposable
- Compatible with **FillSafe™** and **FuelTrack™** systems

Mass (with plug): 3.4 kg (7.5 lbs)



AUS25A Vent with AUS25AA-1 Coupling



BRM23 Receiver

Q (L/min)	HL (kPa)
200	28
250	39
300	50
350	62
400	76
450	91
500	107
550	124
600	143
650	163
700	183
750	206
800	229

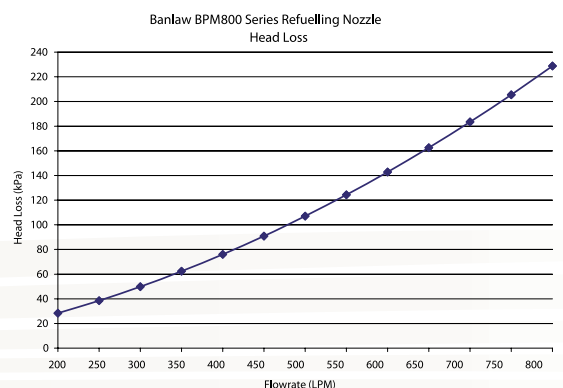

LEGEND:

- 1) All flow tests conducted using DIESELINE fuel (SG=0.84, 5.5cSt nom.)
- 2) Head Loss (HL) includes Banlaw AUS23 Receiver (results will vary with other make)
- 3) All gauge pressure measured within 2" bore



Nozzles

Rail



BPR800 Nozzle



AUS23R Receiver



AUS25R Vent with AUS25AA-1 Coupling

Hydraulic



BPH800 Nozzle



AUS23B Receiver



AUS25A Vent with AUS25AA-1 Coupling

How to use your Banlaw nozzle



1 Wipe the receiver with a clean rag to remove dust & contaminants.



2 Remove the nozzle from the holster. Ensure the handle is locked in the OFF position. Retract the actuator and push the nozzle on to the receiver. Release the actuator to lock it on.



3 Turn on the nozzle by pulling the trigger and rotating the operating handle to the ON position. If necessary, press the START button to start the pump.



4 Remove the nozzle by retracting the actuator. If necessary, press the STOP button to stop the pump.



5 Put the nozzle back in the holster and lock in place. Check the drive away indication light to make sure the nozzle is locked in place.



6 Put the receiver cap back on to prevent contamination.

Filtered Vents

Protect your fuel system from the damaging effects of airborne particle contamination.

Filtered Vents

Heavy equipment typically operates in dusty, dirty conditions. Banlaw's filtered vent comes with a serviceable air filter within the vent cap to prevent particles from entering the tank.

- Extend the life of your fuel filters
- Reduce the incidence of blocked filters and equipment downtime.



BP125A Vent Shown

High Quality Filter Element

- 10µm nominal rating
- Triple layer multi density foam
- Excellent chemical resistance
- Positive seal between mating surfaces
- Field serviceable
- High flow capability with low restriction
- High retention capacity & extended service life.

Features:

- Suitable for flat or round top fuel tanks
- Vapour relief pressure approximately : 110 kPa (Red cap) and 49kPa (Green cap)
- Minimum 3/4" N.B. throughout
- 1/16" bleed hole
- Splash tube (except on Rail spec vents)
- 2" NPT male tapered threads
- 'O' Ring seals provide reliable & extended service
- Relief valve exhaust bypasses filter element.

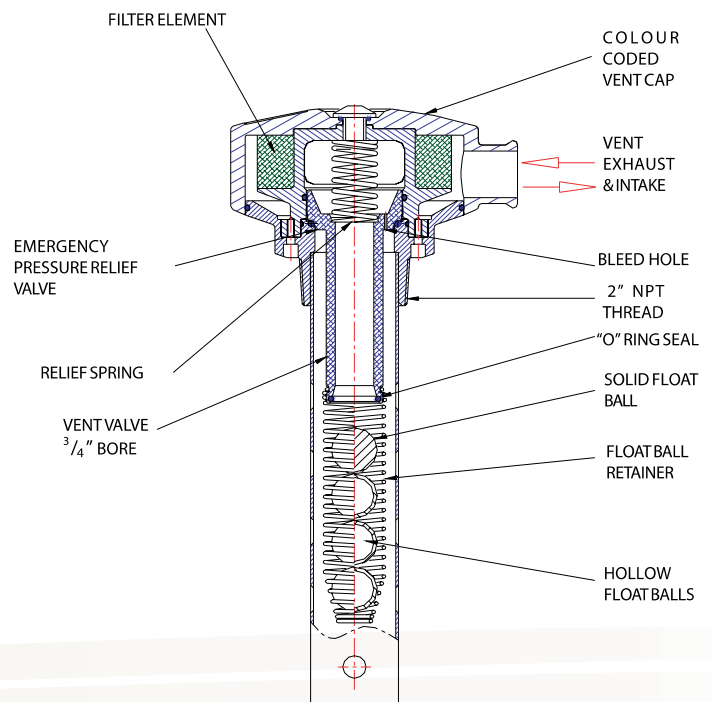



Standard Vents

Manage flow rates to ensure protection from overflow in any operating environment.

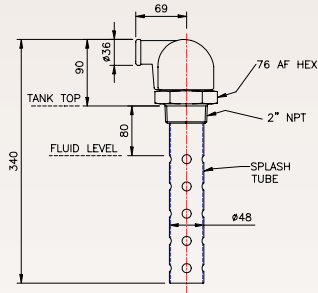

AUS25A and AUS25A-L

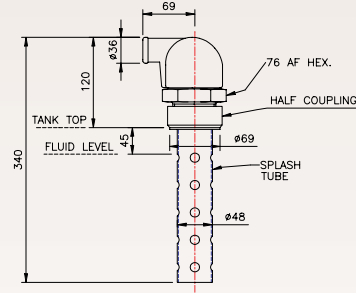

AUS25A-A-L (with half coupling)

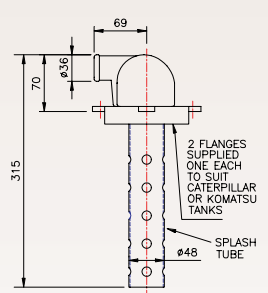

AUS25B



AUS25A Vent



AUS25A-A-L Vent



AUS25B Vent

Flexible vent solutions

- A flexible and complete range of vents for all applications and OEMs.

Faster refuelling

- A Banlaw vent will cater for refuelling rates of ≤ 800 LPM (211GPM).

Rugged construction

- High quality and built tough
- Made from cast aluminium. No plastic.

No spill

- Patented splash tube ensures the correct operation of the float balls at all times
- Reliable and durable o'ring seals provide superior performance and service life. Guaranteed sealing under filling.

Vent Accessories

Used to assist in the installation and correct positioning of vents to various tanks.

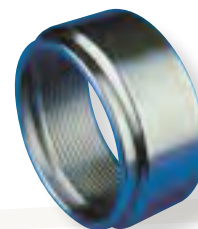

AUS25AA-1 Vent Half Coupling



AUS25A015 Vent Box

Standard Vents

Standard Vents

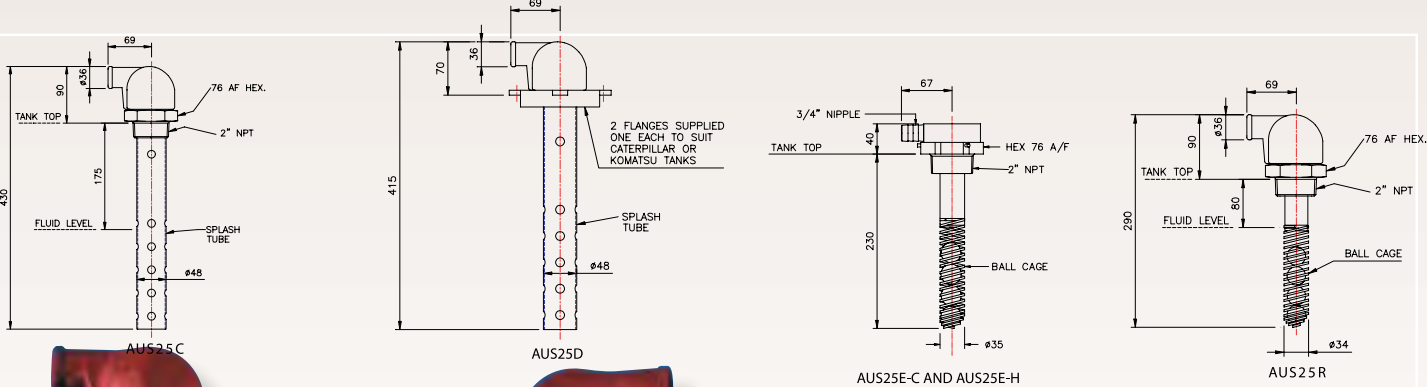

AUS25C Vent



AUS25D Vent



AUS25E-C Vent

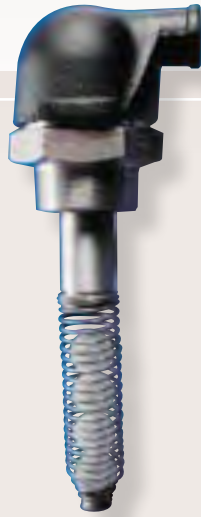

AUS25R Vent

Vent Configuration	Vent Product Numbers							
	To Suit Flat Top Tanks		To Suit Round Top Tanks		Low Profile Mining		Railways	
2" NPT	AUS25A	AUS25A-L	-	-	-	-	-	AUS25R
2" NPT Extended Vent	-	-	AUS25C	AUS25C-L	-	-	-	AUS25C-R
With Half Coupling	AUS25A-A	AUS25A-A-L	AUS25C-A	AUS25C-A-L	-	-	-	-
2" NPT With Hose Tail	AUS25A-C	AUS25A-C-L	AUS25C-C	AUS25C-C-L	AUS25E-H	AUS25E-C	-	-
Flanged (Tamper Proof)	AUS25B	AUS25B-L	AUS25D	AUS25D-L	-	-	-	-
Flanged with Hose Tail (Tamper Proof)	AUS25B-C	AUS25B-C-L	AUS25D-C	AUS25D-C-L	-	-	-	-
Filtered Vent	BP125A	BP125A-L	BP125C	BP125C-L	-	-	-	BP125R

Vent cap colour indicates relief pressure setting: ■ 110kPa - (16psi) ■ 49kPa - (7psi)
 *Note: AUS25E Series Vents supplied only with Gold coloured steel caps



Accessories

High quality accessories to ensure you get the best from your refuelling system.

Banlaw Accessories

Banlaw's receivers, swivels, valves and anchors are made from the highest quality materials like zinc plated steel and anodized aluminium to ensure they withstand harsh everyday treatment.

Caps provide protection when the nozzle and receiver are not connected. Made from aluminium or polyurethane, they are light and durable.

Prolong the life of your equipment by only using Banlaw accessories.

We recommend the use of caps for all receiver and plugs for all nozzles to protect your equipment and prevent contamination.

ACCESSORIES

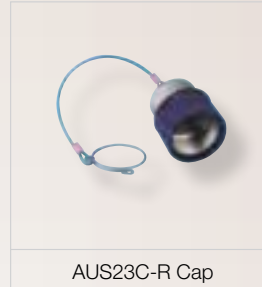

AUS23C-R Cap



AUS23C Cap



AUS43C Cap



800 Anchor AUS21A049



Breakaway Valve



1000 Anchor AUS22049

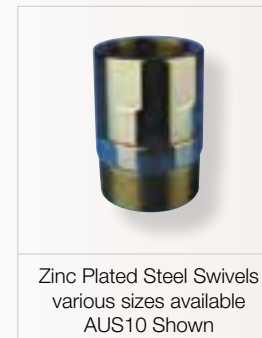

Zinc Plated Steel Swivels
various sizes available
AUS10 Shown



Anodized Aluminium Swivels
various sizes available
AUS50 & AUS52 Shown



AUS24A
Shell Receiver & Cap



Partial Hex
Receiver Socket
(AUS23SOCKET)

Full Hex
Receiver Socket
(AUS-RSOCKET)

BANLAW
"innovative refuelling specialists"

REFUELLING NOZZLE INSTRUCTIONS

STEP 1
1.1 REMOVE RECEIVER CAP.
1.2 REMOVE NOZZLE FROM ANCHOR OR PLUG FROM FRONT OF NOZZLE.
1.3 ENSURE MATING SURFACES OF RECEIVER AND NOZZLE ARE CLEAN AND UNDEFORMED.

STEP 2
2.1 ENSURE OPERATING HANDLE IS LOCKED IN THE OFF POSITION.
2.2 RETRACT ACTUATOR AND PUSH NOZZLE FIRMLY ONTO THE RECEIVER.
2.3 RELEASE ACTUATOR AND PUSH NOZZLE FIRMLY ONTO RECEIVER.
2.4 REPEAT STEPS 2.2 AND 2.3 UNTIL NOZZLE IS SECURELY CONNECTED.

STEP 3
3.1 RELEASE CATCH USING TRIGGER AND ROTATE HANDLE INTO ON POSITION.
3.2 NOZZLE WILL AUTOMATICALLY TURN OFF AFTER TANK VENT HAS CLOSED.
3.3 DO NOT MANUALLY HOLD NOZZLE IN THE ON POSITION DURING REFUELLING OR AFTER TANK VENT HAS CLOSED.

STEP 4
4.1 ENSURE OPERATING HANDLE IS LOCKED IN THE OFF POSITION.
4.2 RETRACT ACTUATOR AND REMOVE NOZZLE FROM RECEIVER.
4.3 RETURN NOZZLE TO ANCHOR OR REPLACE NOZZLE PLUG.
4.4 REPLACE RECEIVER CAP.

PROMPTLY REPORT ANY PROBLEMS TO YOUR SUPERVISORS
www.banlaw.com "The Refuelling Specialists"

Operation Sign AUSOPSIGN-2

Check Valve Fuel Receiver

The best anti-theft mechanism

Banlaw Check Fuel Valve Receiver *

The unique, patented design of the Banlaw Check Valve Receiver is unlike any other product on the market.

- Banlaw's Check Valve Receiver cannot be over-ridden, eliminating fuel theft via the receiver
- Intelligent design of the flow path generates low pressure. This prevents the increased risk of premature shut-off of pressure sensitive refuelling nozzles
- Versatile design allows installation either directly into the fuel tank or the pipework (min 2")
- Manufactured to exacting standards using high quality materials to withstand harsh operating environments
- The receiver body can be replaced without the need to drain the tank
- Model available to suit Banlaw FuelTrack™ auto ID system.

*International patent pending

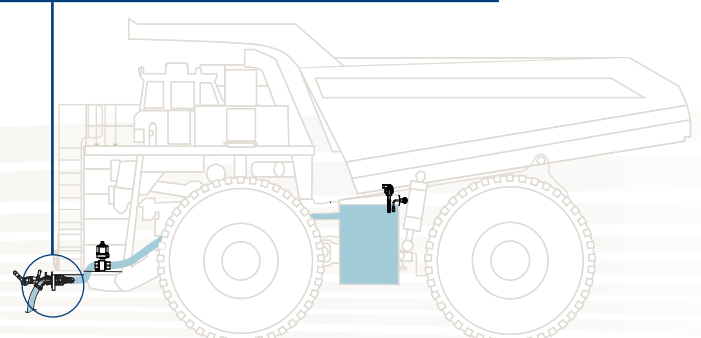
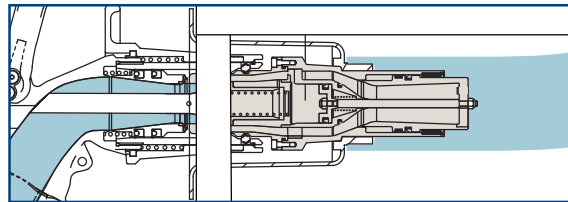
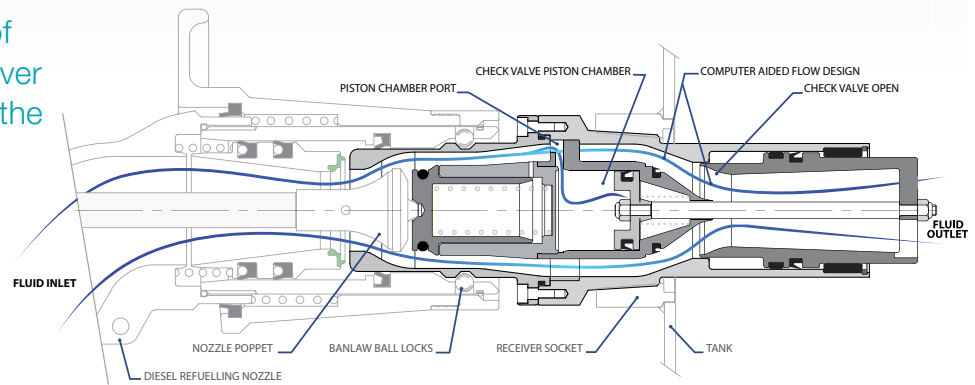

The associated diagram is for illustration purposes only and is not to scale

Check Valve Fuel Receiver



Nozzle **Holster**



Part No. BFTNH



Protect nozzles and minimise contamination

Nozzle Holster

Banlaw Nozzle **Holster**

Leaving a nozzle on the ground increases the risk of it being cracked or worn. It also increases dirt and contaminants that can end up in your fuel. Banlaw's nozzle holster keeps nozzles safely off the ground.

The holster also has an integrated drive-away notification system. If the nozzle is not placed correctly in the holster or is still connected to the truck the driver is alerted by an alarm.

Lube**Central**™ FlushFace

Minimise contamination and increase flow rates during fluid transfer

Lube Central

Higher flow capability

Available in NPT thread sizes to suit current industry specifications and larger configurations to maximise flow-rate capability.

Flush face design

- Minimises contamination
- Reduces wear on mating seals and other components.

Push to connect system

- There is no need to retract the actuator collar during connection making them easier to use, particularly in tight confines.

Colour coded

- For easy identification.

Durable

- Ball lock latching mechanism for a stronger connection
- Unique Dry Break technology eliminates spillage
- Constructed from brass, zinc plated steel or anodized aluminium.

LubeCentral™ FlushFace

Receiver dust caps available

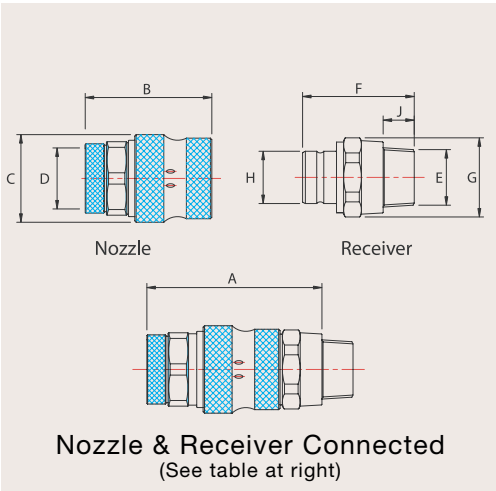

Fitting Type	Dimensions								
	A	B	ØC	D	E	F	G	ØH	J
BPLR1	91.5	64	46	*	*	63	41	24	20
BPLN1									
BPLR2	93.5	65	48	*	*	66	46	25	21
BPLN2									
BPLR3	97.0	68	50	*	*	67.5	46	28	21
BPLN3									
BPLR4	110.5	76.5	55	*	*	75.5	50	31.5	21
BPLN4									
BPLR5	115.5	80	58	*	*	79	53	33	22
BPLN5									
BPLR6	124.0	89.5	62	*	*	79	56	37	22
BPLN6									

Thread Configurations - Receivers (Male) - Nozzles (Female)
Size 1 Couplings available with 1/2" & 3/4" on Receiver and 3/4" & 1" on Nozzle
Size 2,3,4 & 5 Couplings available with 3/4" & 1" on Receiver and Nozzle
Size 6 Couplings available with 1" & 1-1/4" on Receiver and Nozzle

On Vehicle Locations for LubeCentral™ Service Box

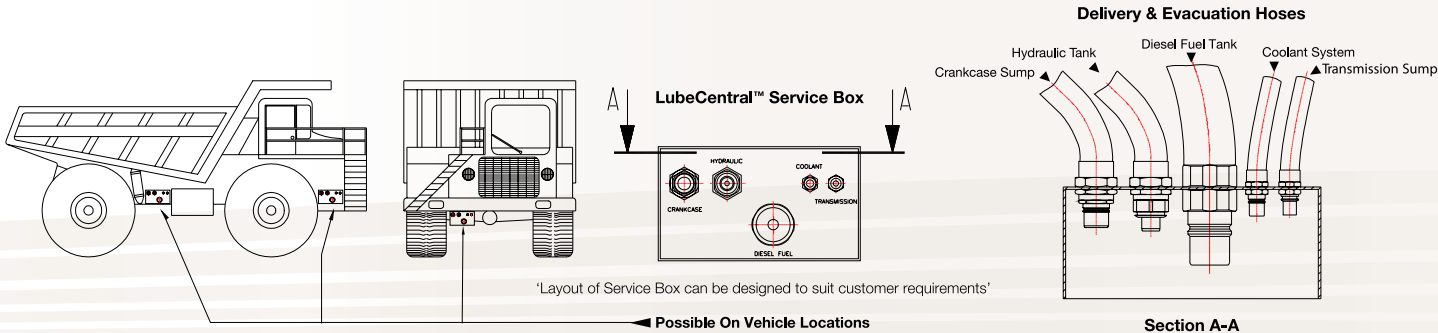



Classic Range

Crankcase

Classic, tough fittings for every job



Banlaw Classic Range

- Ball lock latching mechanism for a stronger connection between nozzle and receiver
- Delivery of a higher safe working pressure for increased safety
- Unique Dry Break technology eliminates spillage

AUS27W & AUS29W shown with optional Caps/Plugs

AUS29L shown with optional Plug

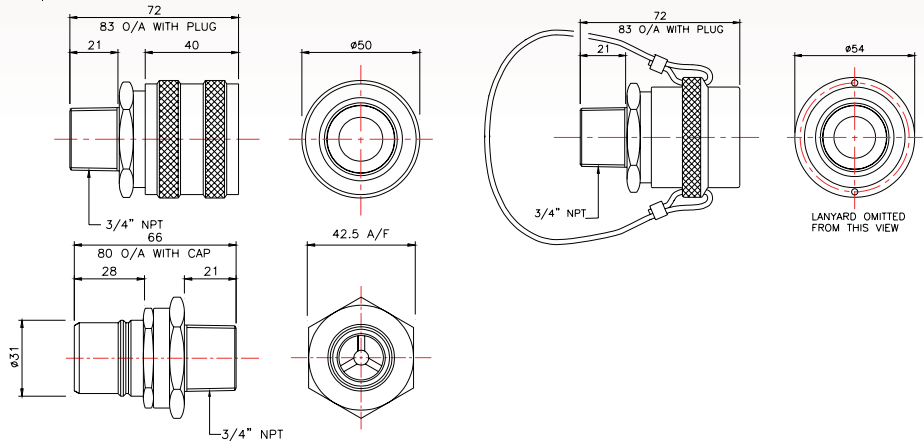

- Commonly used to fill and evacuate crankcase oils
- Safe Working Pressures
 - AUS27W : 10 MPa (1450 psi)
 - AUS29W & AUS29L : 3 MPa (435 psi)
 - Coupled Nozzle & Receiver : 4.75 MPa (690 psi)
- Max. recommended flow rate : 100 LPM (26.4 GPM) - ISO 46 oil

Technical Specification

1. A safety factor of approx. 4 has been applied to the burst pressure in order to obtain the Safe Working Pressures (S.W.P.) quoted for the Classic Range

2. Unless noted otherwise, all fittings are manufactured from zinc plated steel components, fitted with Viton seals. All plugs and caps are manufactured from Acetal (plastic).

Part Numbers

Type	Basic Fitting	Tailpiece			Additional Part	
		1/2" NPT	3/4" NPT	1-1/16" JIC	Plug	Cap
Crankcase	AUS27W	27W-B	STD	27WB/H	-	AUS27W-C
	AUS29W	29W-B	STD	29WB/H	AUS29W-P	-
	AUS29L	29L-B	STD	29LB/H	AUS29L-P	-

STD: supplied as standard - option not applicable

Lube Central

Classic Range

Hydraulic

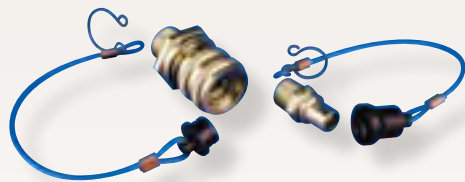

AUS32W & AUS33W
shown with optional Caps/Plugs

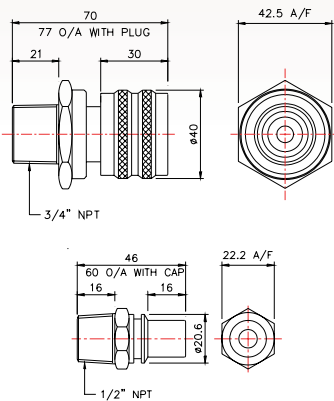

Transmission

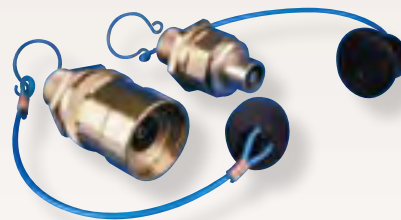

AUS34A & AUS41A
shown with optional Caps/Plugs

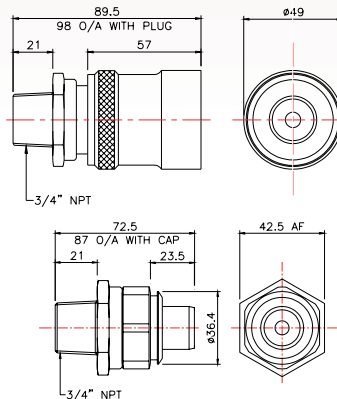

Coolant

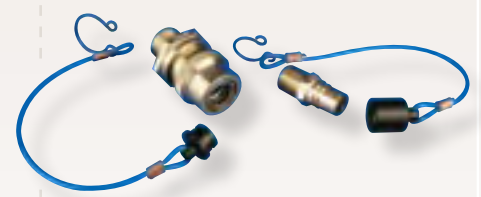

AUS36A & AUS37W
shown with optional Caps/Plugs

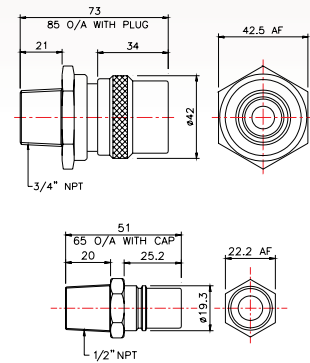

- Commonly used to fill and evacuate hydraulic oils
- Safe Working Pressures
AUS34A : 10 MPa (1450 psi)
AUS41A : 10 MPa (1450 psi)
Coupled Nozzle & Receiver :
4.0 MPa (580 psi)
- Max. recommended flow rate :
100 LPM (26.4 GPM) - ISO 46 oil

- Commonly used to fill and evacuate transmission oils
- Safe Working Pressures
AUS32W : 4.25 MPa (615 psi)
AUS33W : 10 MPa (1450 psi)
Coupled Nozzle & Receiver :
11.5 MPa (1670 psi)
- Max. recommended flow rate :
30 LPM (7.9 GPM) - ISO 46 oil

- Commonly used to fill and evacuate coolant fluids
- Safe Working Pressures
AUS36A : 10 MPa (1450 psi)
AUS37W : 10 MPa (1450 psi)
Coupled Nozzle & Receiver :
7.5 MPa (1090 psi)
- Max. recommended flow rate :
40 LPM (10.6 GPM) -
Water (estimated)

Part Numbers

Type	Basic Fitting	Tailpiece			Additional Part	
		1/2" NPT	3/4" NPT	1-1/16" JIC	Plug	Cap
Transmission	AUS32W	32W-B	STD	32WB/H	AUS32W-P	-
	AUS33W	STD	-	33WB/H	-	AUS33W-C
Hydraulic	AUS34A	*	STD	34AB/H	AUS34A-P	-
	AUS41A	*	STD	41AB/H	-	AUS41A-C
Coolant	AUS36A	36A-B	STD	36AB/H	AUS36A-P	-
	AUS37W	STD	-	37WB/H	-	AUS37W-C

*Not Standard Product - But can be supplied on request.
STD: supplied as standard - option not applicable



Classic Range

Push to Connect



AUS39W & AUS38W Assemblies
AUS38W shown with optional Cap

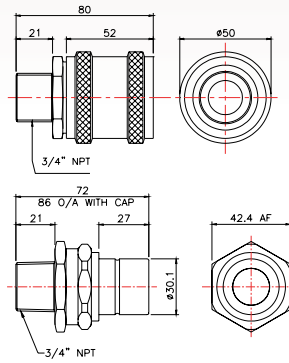

Classic,
tough fittings
for every job

- Commonly used to fill and evacuate oils
- Safe Working Pressures
AUS38W : 10 MPa (1450 psi)
AUS39W : 1.5 MPA (217 psi)
Coupled Nozzle & Receiver :
10 MPa (1450 psi)
- Max. recommended flow rate :
100 LPM (26.4 GPM)
- ISO 46 oil

R Series Alternative Fittings



AUS81A (R17) & AUS80A (R18)
shown with optional Cap/Plug

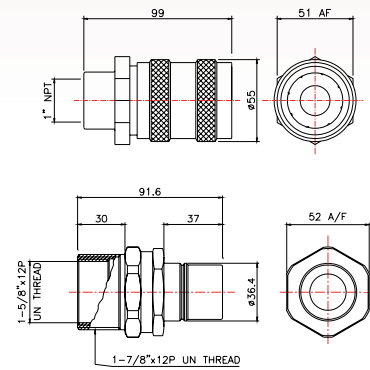

- Alternative higher flow fittings used to fill and evacuate oils
- Safe Working Pressures
AUS80A : 6 MPa (870 psi)
AUS81A : 2.5 MPA (365 psi)
Coupled Nozzle & Receiver :
2.5 MPa (365 psi)
- Max. recommended flow rate :
180 LPM (47.6 GPM) - ISO 46 oil

Part Numbers

Type	Basic Fitting	Tailpiece			Additional Part	
		1/2" NPT	3/4" NPT	1-1/16" JIC	Plug	Cap
Push to connect	AUS38W	*	STD	38WB/H	-	AUS38W-C
	AUS39W	*	STD	39WB/H	-	-
Alternative	AUS80A	-	-	-	-	AUS80A-C
	AUS81A	-	-	-	AUS81A-P	-

*Not Standard Product - But can be supplied on request.
STD: supplied as standard - option not applicable

Classic Range

Grease



AUSGRC Receiver Cap AUSGR Receiver AUSGN Nozzle AUSGNP Nozzle Plug

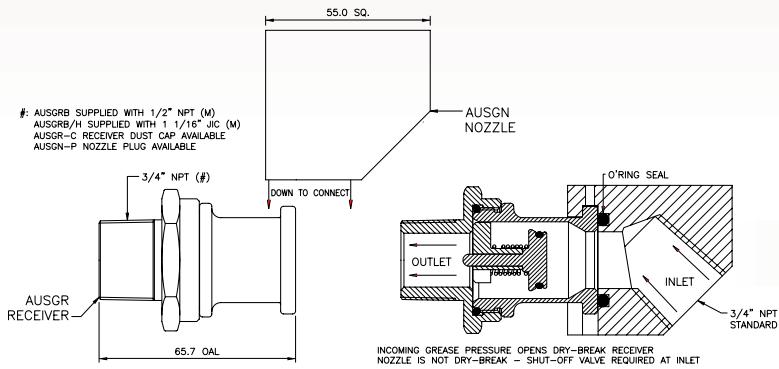

One Way Valve



AUS3W

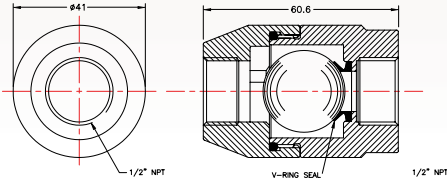

Oil Sample Valve



AUSV3

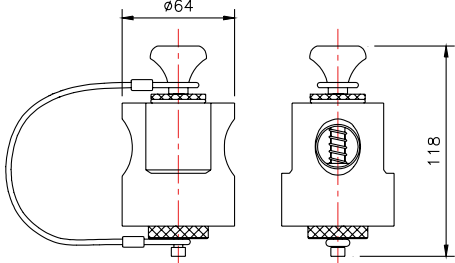

- Banlaw AUSGR & AUSGN fittings are specifically designed for the bulk transfer of grease
- Provides ease of connection
- Able to connect/disconnect under pressure, utilising a standard off the shelf valve on the delivery line
- Robust, zinc plated
- Easy to use

Part Numbers

Type	Nozzle	Receivers				Additional Part	
		3/8" NPT	1/2" NPT	3/4" NPT	1-1/16" JIC	Plug	Cap
Grease	AUSGN	AUSGRN	AUSGRB	AUSGR	AUSGRBH	AUSGNP	AUSGRC

Banlaw can help you to achieve improved:

- fuel security
- environmental performance
- cost control
- contamination control
- custody transfer
- compliance to assist with managing fuel tax credits and carbon trading schemes.

Distributed Worldwide



Contact us

For information on the complete range of Banlaw products and services or for product updates please call us or visit our website.

Banlaw's extensive worldwide network of distributors and repairers can also offer prompt, factual, technical advice and product support.

Call for a full consultation. **Banlaw** Pty. Ltd.

Unit 1/3 Auchinraith Estate, Blantyre, Scotland, G72 0NJ

t: +44 (0)1698 824431 f: +44 (0)1698 826725

w: www.banlawsystems.com e: info@banlawsystems.com

ABN 88 062 044 071

September 2008



Call your authorised **BANLAW** agent